

# PRODEMAND

YMMS: 2006 Chevrolet Cobalt SS  
Engine: 2.4L Eng  
VIN:

Feb 24, 2022  
License:  
Odometer:

## ENGINE PERFORMANCE > 2.4L VIN B

Fig 1: 2.4L VIN B, Engine Performance Circuit (1 of 4)

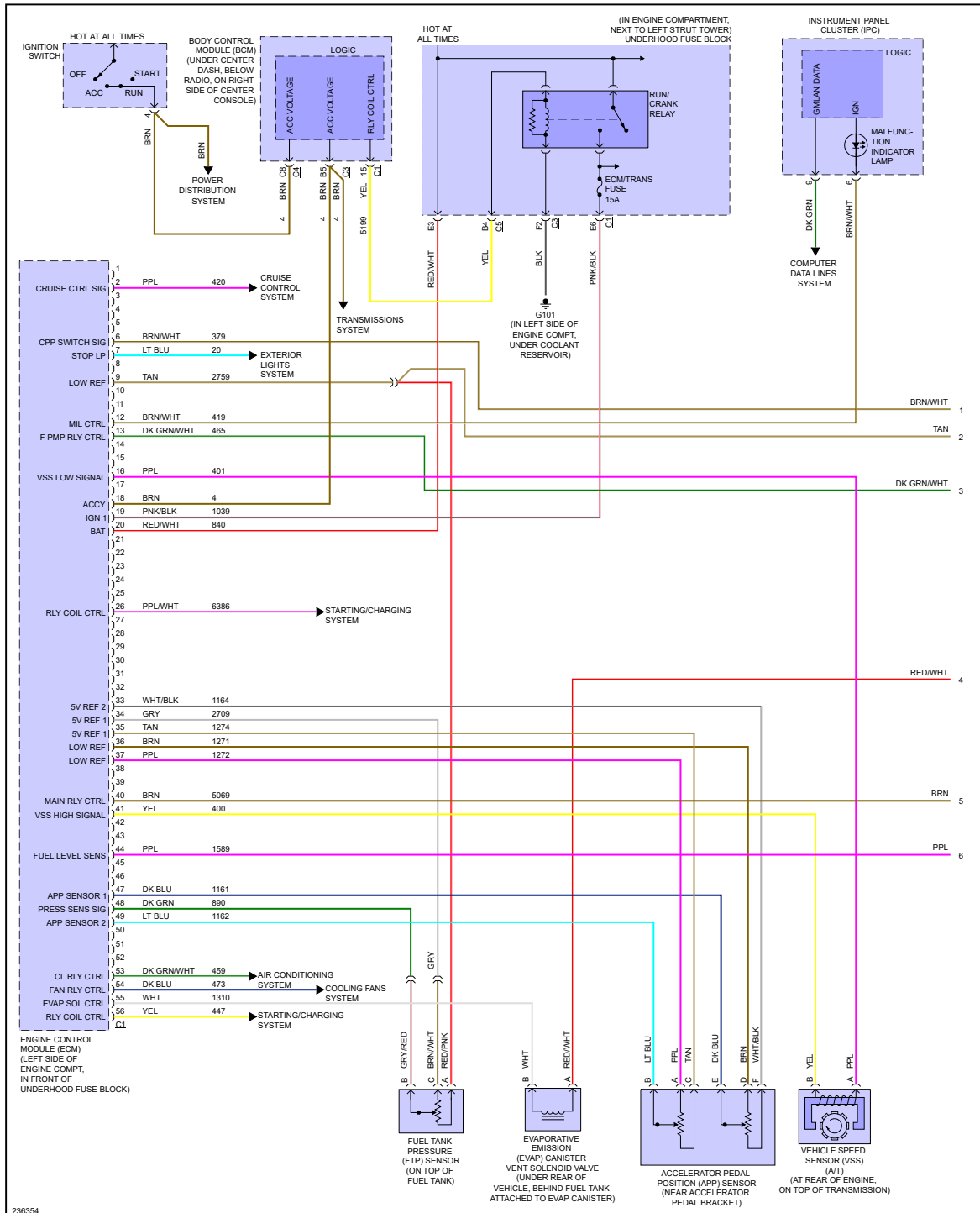

236354

Fig 2: 2.4L VIN B, Engine Performance Circuit (2 of 4)

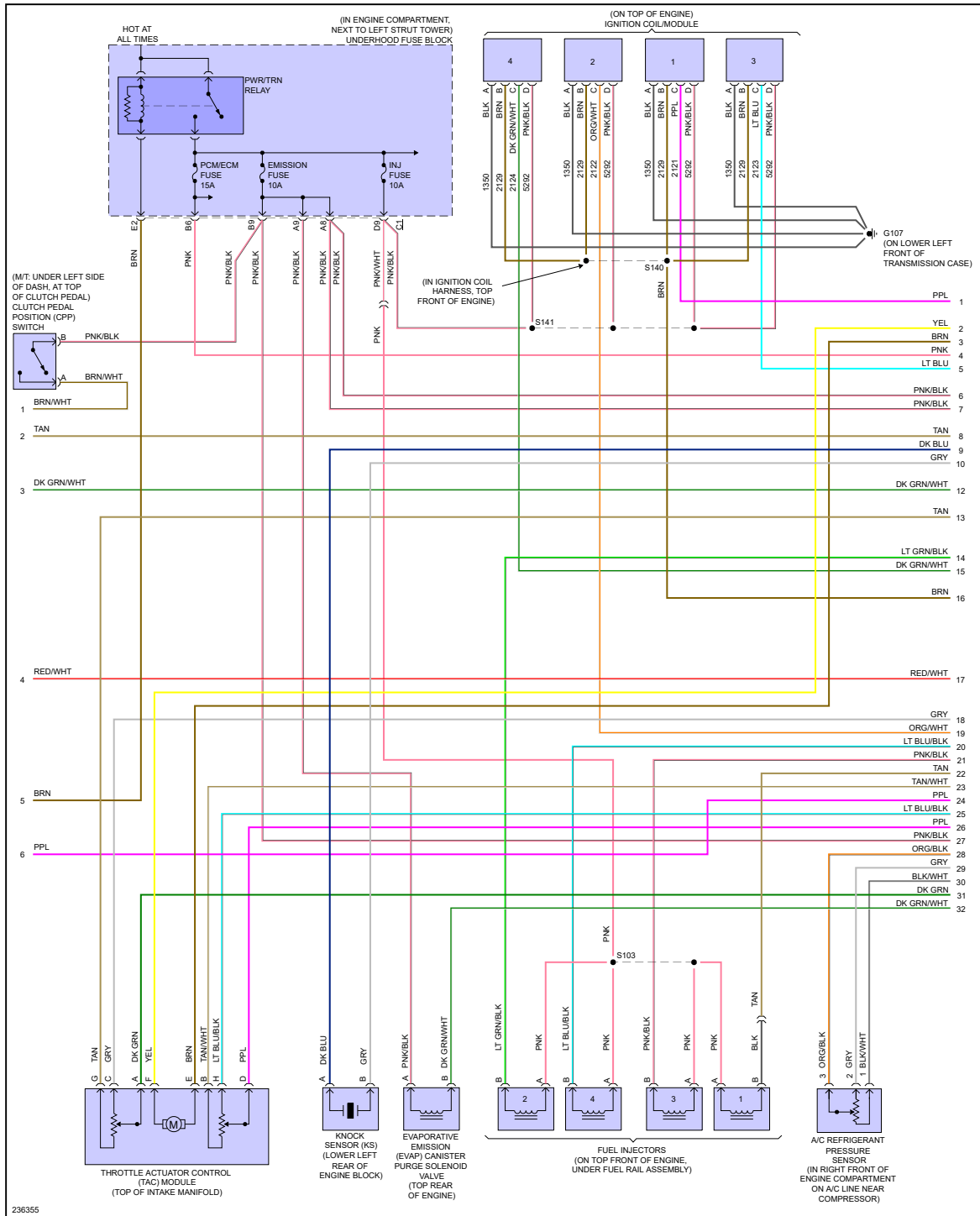

Fig 3: 2.4L VIN B, Engine Performance Circuit (3 of 4)

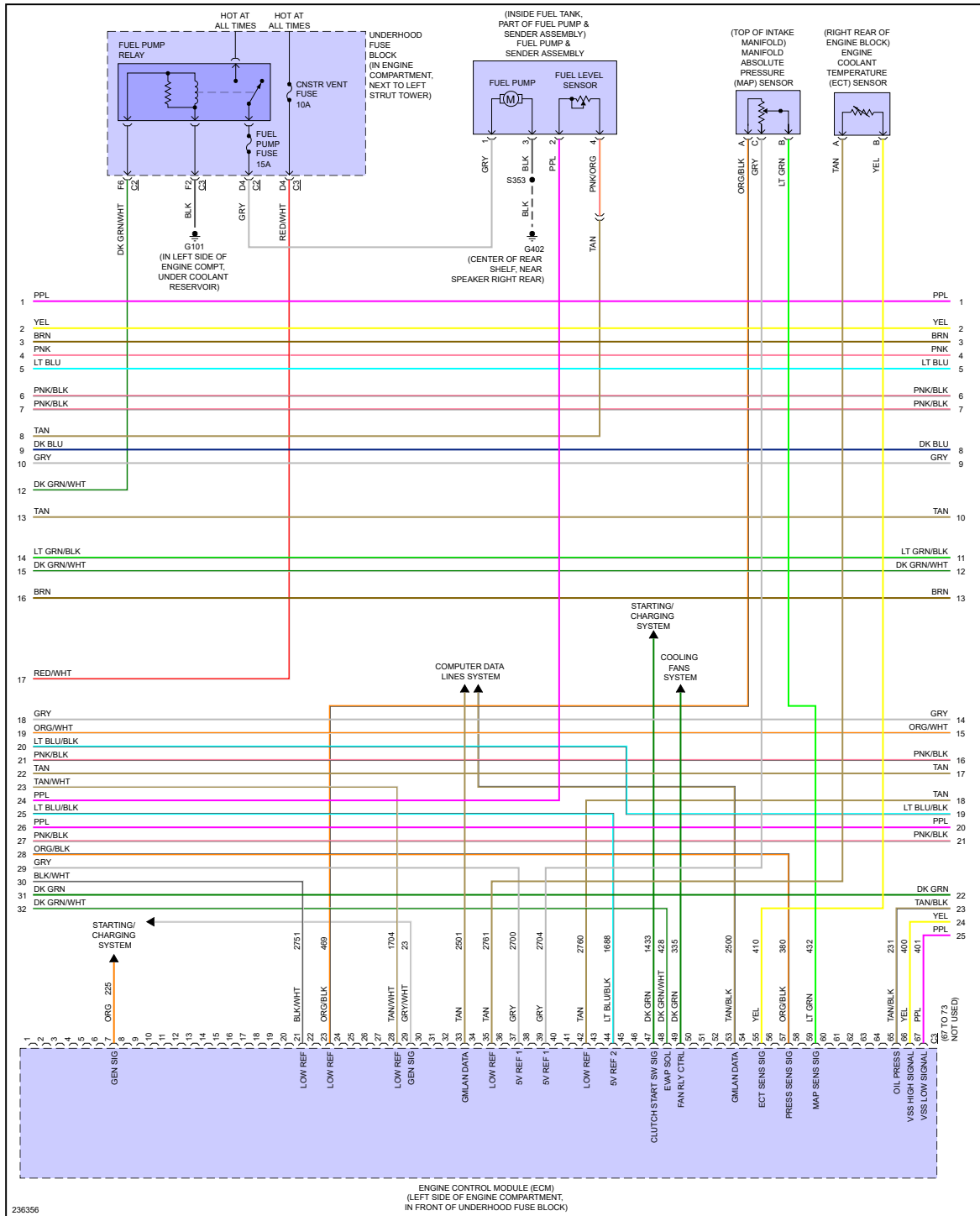

Fig 4: 2.4L VIN B, Engine Performance Circuit (4 of 4)

